

Traditional Product Range Horizontal Slider

A slim and versatile horizontal sliding system that provides easy access for cleaning and ventilation, it is suitable for treating most window types. Available with 2, 3, 4 or 5 sliding sashes (panels).

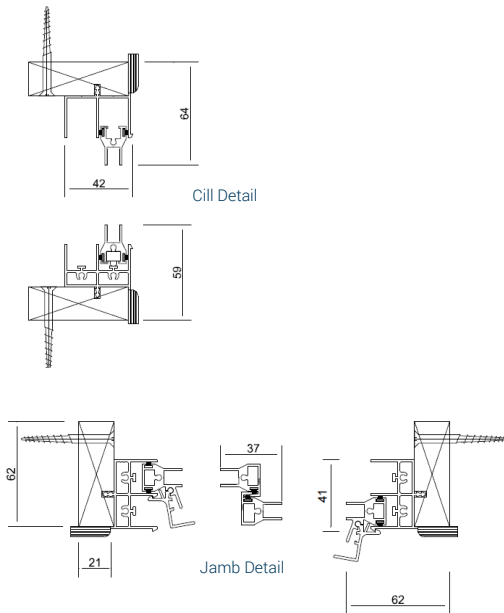

Features

- Slim, unobtrusive aluminium profile
- Smooth sliding action on panels for easy operation using brass wheels
- All panels lift out for complete access to the primary window
- Improved noise and thermal installation
- Suitable to have bevelled timber subframe to fix into bays /splayed reveals
- Can be coupled or stacked with other units in the range to treat large areas of glazing or long runs of windows
- Available in right hand (RH) or left hand (LH) orientation

Variations of Basic Unit

- Locking and non-locking fitch lock available to secure panels (fitted to the interlock sections)
- Standard and acoustic trickle vents are available
- Can be coupled and stacked using a heavy duty frame coupling section or timber to timber
- Unit available with no subframe
- Larger PVCu trims and timber trims available at an additional cost
- Variety of stock colours available, including all RAL options
- Can accept flyscreen mesh

Specification

- Glazing options: 4mm - 6.8mm
- Choice of timber subframes
- Pre-drilled and countersunk to suit either face fix or reveal fix
- Woolpile inserted into panel section groove to create outer frame seal
- Gasket colour option of black or white
- PVCu trims supplied for the face of the units to create a neat, clean finish
- Standard colour - white high gloss - RAL 9910



Optimum Noise Reduction: 52dB (Rw)

Using 6.4mm acoustic laminate glazing, with 200mm glass-to-glass



Optimum U Value: 1.868 W/m²K

Using 4mm toughened Low E glazing, with 80mm glass-to-glass

Traditional Configurations

Based on 4mm Glass

Max width:
or Max height:

	SS2	C03 (Centre Opening)	SS3	SS4	SS5
Max width:	2,400mm	3,600mm	3,600mm	4,900mm	4,900mm
or Max height:	1,800mm	1,800mm	1,800mm	1,800mm	1,800mm